

# **MATRIXBOX** MX2400 SERIES

## Hardware Manual

Revision 2024.3.7

# Table of Contents

1	Introduction .....	3
2	Main .....	4
2.1	Features.....	4
2.2	Electrical characteristics .....	4
2.3	Front panel.....	4
2.4	Rear panel .....	7
2.5	Supported cards .....	9
2.6	Power supplies.....	9
2.7	Rack Box extension.....	10
2.8	Dimensions .....	11
3	Cards .....	12
3.1	MXC2-MASTER .....	12
3.2	MXC2-DEV-4/2/2.....	14
3.3	MXC2-DEV-4D .....	17
3.4	MXC2-LCMX-32.....	19
3.5	MXC2-HCMX-16 .....	22
3.6	MXC2-DIO-64 .....	25
3.7	MXC2-DIO-64I.....	27
3.8	MXC2-DI-ISO-32 .....	29
3.9	MXC2-DO-ISO-32 .....	31
3.10	MXC2-BUSEX.....	33

# 1 Introduction

MX2400 is a rack for the matrix (scanner) cards, connection of the measuring devices and connection of the testing adapter with DUT.

To control MX2400 from the FPC funTEST software is necessary the plugin. For reference, see the MX2400 Programmer's Manual.

In this hardware manual are described all available cards including the internal connection to the MX2400.



## Caution

Because of the possibility of electrical shock, it is not allowed to use the MX2400 without all card's position equipped - by cards or blanks.

## 2 Main

### 2.1 Features

- 19" rack size
- Maximum of 544 test-points in one box, up to 1120 when joining two boxes
- Ethernet (main communication interface)
- RS232 (service interface)
- Four internal signal buses
- Fast signal switching
- High flexibility of the internal routing
- Self diagnostic functionality
- Integrated pin-probe functionality
- Integrated digital input and output interface
- Hardware triggering (measuring <> switching)
- Front panel with the LED indicators
- Power supply 100 -240V 50/60Hz

### 2.2 Electrical characteristics

#### Testing setup

- Measurement path: TP/MXC2-LCMX (position 1) to MEAS/DEV-4/2/2 (position 18)
- Ambient temperature 22°C
- Relative humidity: 50%

#### Parameters

Channel resistance	< 1Ohm
Channel to channel crosstalk	< -40dB @ 1MHz
Channel to channel resistance	> 100GOhm @ 100VDC
Channel bandwidth	3MHz

### 2.3 Front panel

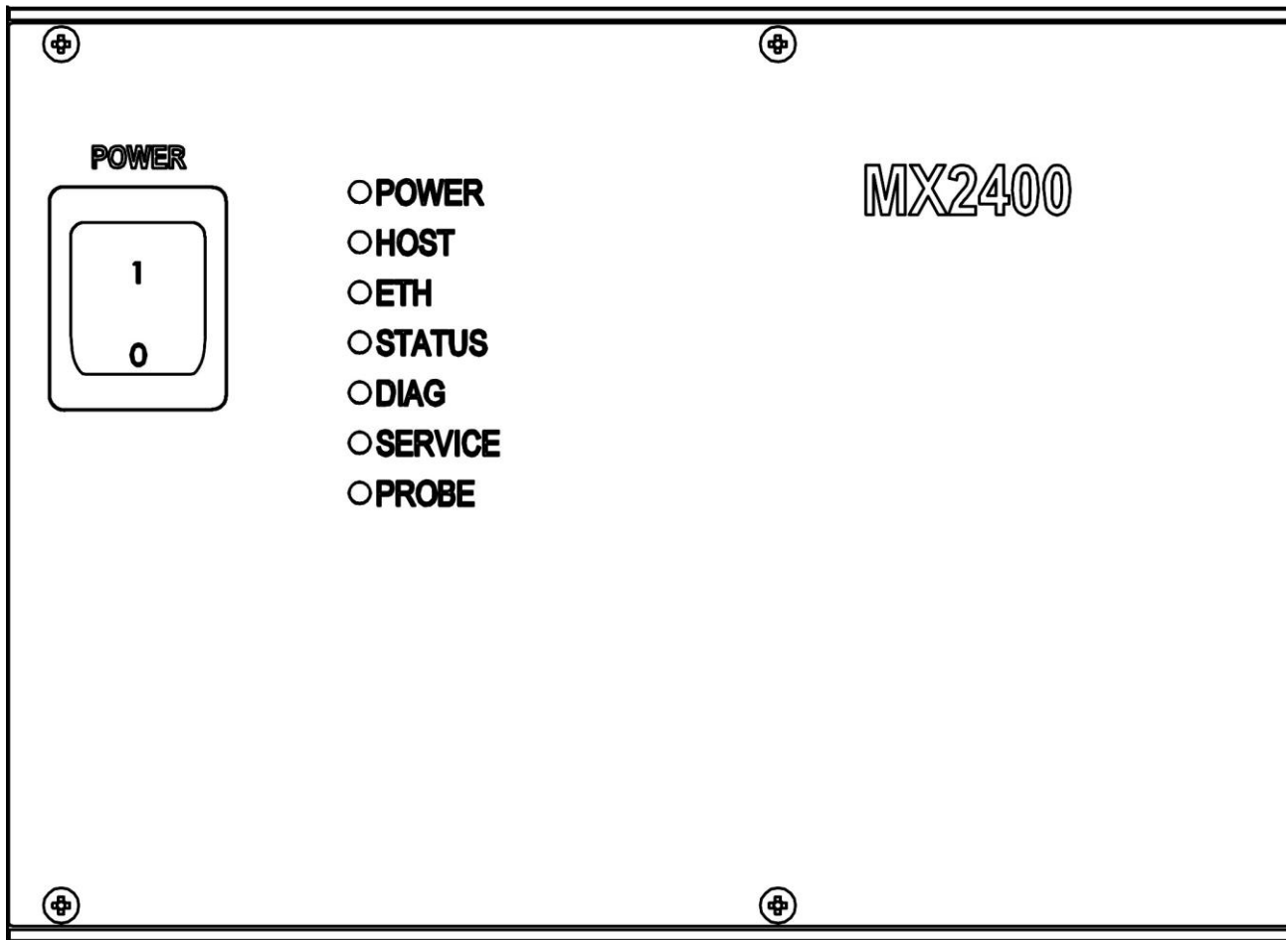

POWER SWITCH

The AC mains switch.

Turns the MX2400 on (1) or off (0). When on, the switch is green back-lighted.

## LEDs

LED	Color	Description
POWER	Green	Power indication of MX2400
HOST	Green	Connection between the MX2400 and the plug-in is active
ETH	Green	Light on: ethernet has the link Blink: ethernet activity (data transmission)
STATUS	Red/Green	Common status of MX2400 None or green: OK Red: FAULT
DIAG	Red/Green	Diagnostics state None: no diagnostics was performed Green: diagnostics OK Red: diagnostics FAIL
SERVICE	Yellow	Maintenance required
PROBE	Yellow	Probe is active

## 2.4 Rear panel

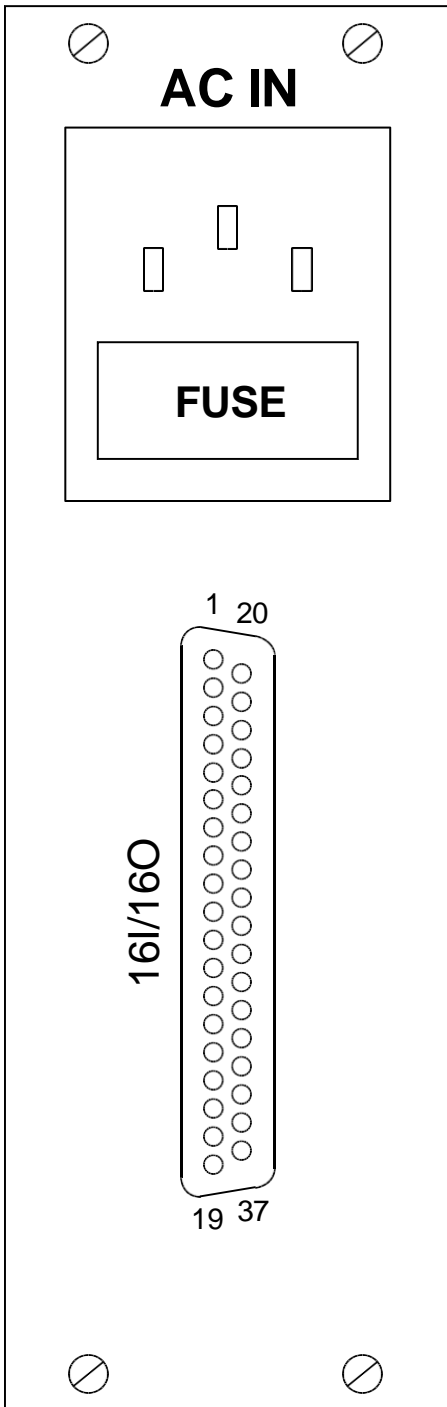

- AC IN** AC mains  
100 - 240 VAC
- FUSE** AC mains fuse  
T/3A
- 16I/16O** Digital optical-isolated IO interface  
16 inputs (active-low) and 16 OC outputs  
Canon 37 female connector (CAN37-F)

**16I/16O pinout:**

Pin	Desc	Pin	Desc
1	IN 0	20	IN 1
2	IN 2	21	IN 3
3	IN 4	22	IN 5
4	IN 6	23	IN 7
5	IN 8	24	IN 9
6	IN 10	25	IN 11
7	IN 12	26	IN 13
8	IN 14	27	IN 15
9	V+	28	N.C.
10	N.C.	29	GND
11	OUT 0	30	OUT 1
12	OUT 2	31	OUT 3
13	OUT 4	32	OUT 5
14	OUT 6	33	OUT 7
15	OUT 8	34	OUT 9
16	OUT 10	35	OUT 11
17	OUT 12	36	OUT 13
18	OUT 14	37	OUT 15
19	N.C.		

V+ is the IO power supply (from the application).  
**V+ range:** +5 to +30V DC (typically +24V)

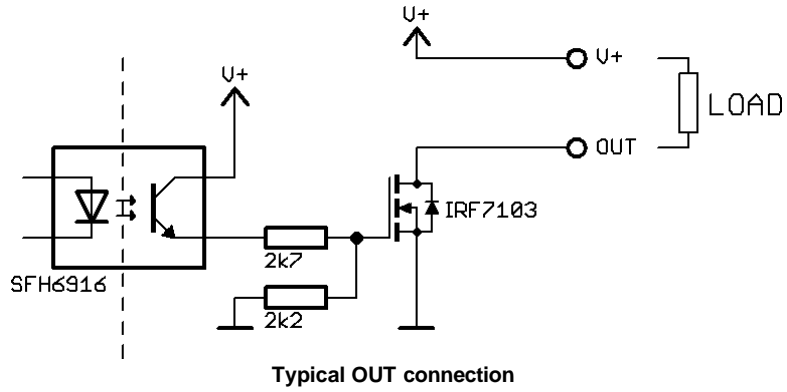
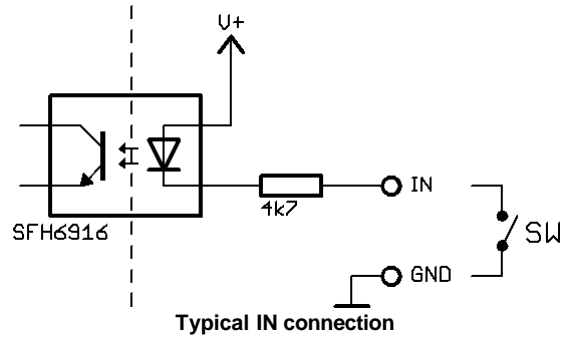



## 2.5 Supported cards

Catalog name	Catalog number	Description
MX2400*	MX2400-MR	Main rack (3U), 17+1 slots for exchangeable cards. Equipped with 5V, 24V and optionally 48V power supplies. Base device contains all necessary buses (power bus, data bus, signal buses 1-4).
MXC2-MASTER*	BOM-0143-01-A	Main controller card.
MXC2-DEV-4/2/2	BOM-0144-01-A	Device multiplex card.
MXC2-DEV-4D	BOM-0177-01-A	Simple device card, low-cost variant of MXC2-DEV-4/2/2.
MXC2-LCMX-32	BOM-0139-01-C	Low-current/low-voltage matrix card with 32TP.
MXC2-HCMX-16	BOM-0167-01-A	High-current/middle-voltage matrix card with 16TP.
MXC2-DIO-64	BOM-0200-01-A	Digital input/output card with 64DIO.
MXC2-BUSEX**	BOM-0213-01-B	Interconnects two MX2400 together as a one device.

\* Mandatory devices

\*\* Mandatory in primary interconnect mode, but in secondary interconnect mode replaces MXC2-MASTER

## 2.6 Power supplies

Each MX2400-MR (master rack) has equipped with following power supplies:

- 5V/5A
- 24V/1,1A
- 48V/1,6A (option)

This must be considered at the set-up the system according to maximum cards power consumption and usage. If there will be more devices in the MX2400 that will drain more current that power supplies can handle, then the system will became unstable.

## 2.7 Rack Box extension

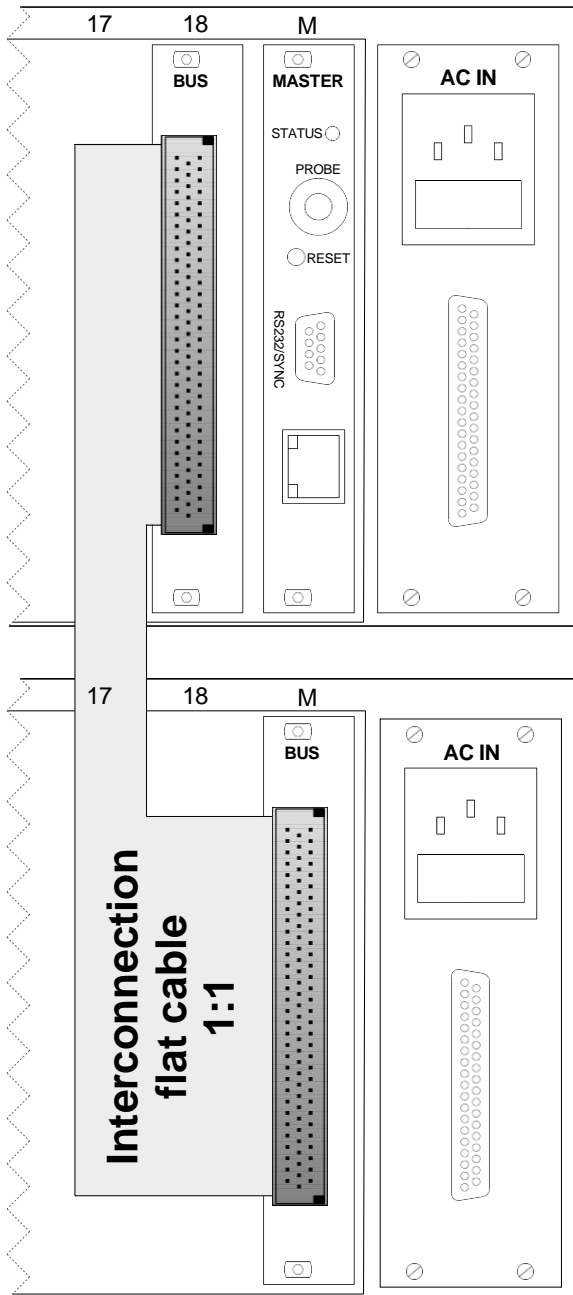

MX2400 box can be easily expanded up to 35 cards by joining another one MX2400 box.

### Hardware setup

#### Primary rack box

[BUS extension card](#) must be placed in slot 18.

#### Secondary rack box

The extension BUS card must be placed instead of master card into the slot "M".

Interconnection between primary and secondary box is done by a 1:1 flat cable (64 wires).

## 2.8 Dimensions

Standard 19" 3U rack.

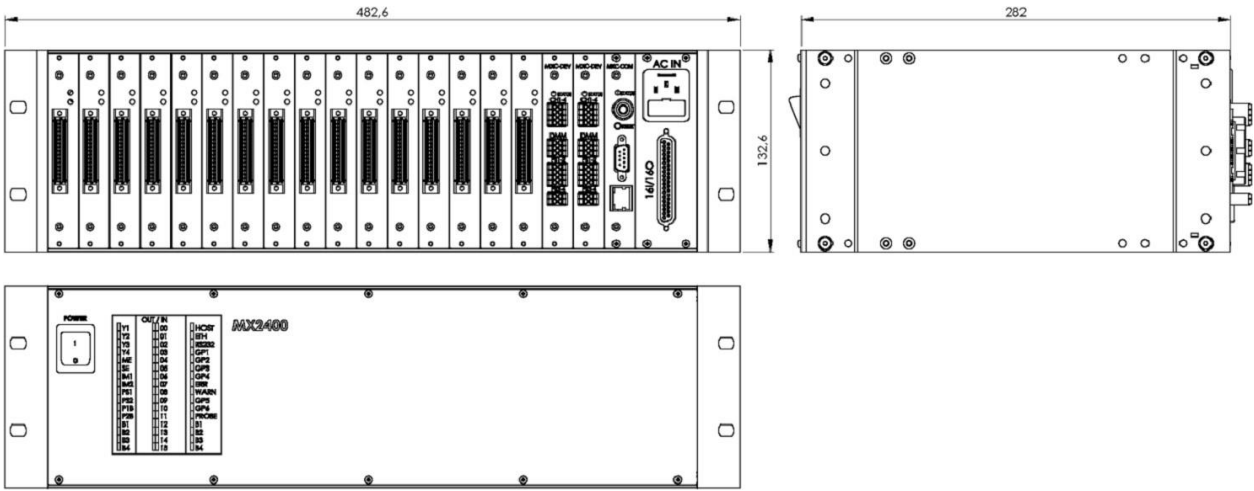

### 3 Cards

#### 3.1 MXC2-MASTER

The main controller card of MX2400 which is responsible for communication with host system via ethernet and communication with other cards. Card features service connection via RS232, PROBE function and DIO interface. This card is required in the system in a reserved location ("M").

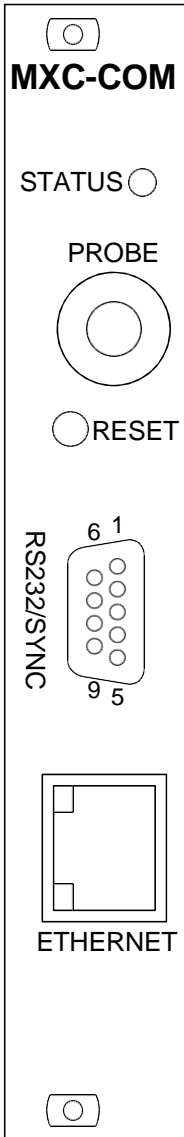

- STATUS** Status LED
- PROBE** Input connector for probe
- RESET** Button for device reset
- ETHERNET** Communication interface between MX2400 and PC  
(standard patch-cord UTP cable can be used, if the other side does not support the Rx <-> Tx switching, then the cross-link cable must be used)

**RS232/SYNC - Connector for service communication and external DMM triggering/synchronization:**

- 1 OUT0 - POS
- 2 RS232 - RX
- 3 RS232 - TX
- 4 OUT0 - NEG
- 5 RS232 - GND
- 6 IN0 - POS
- 7 IN0 - NEG
- 8 IN1 - POS
- 9 IN1 - NEG

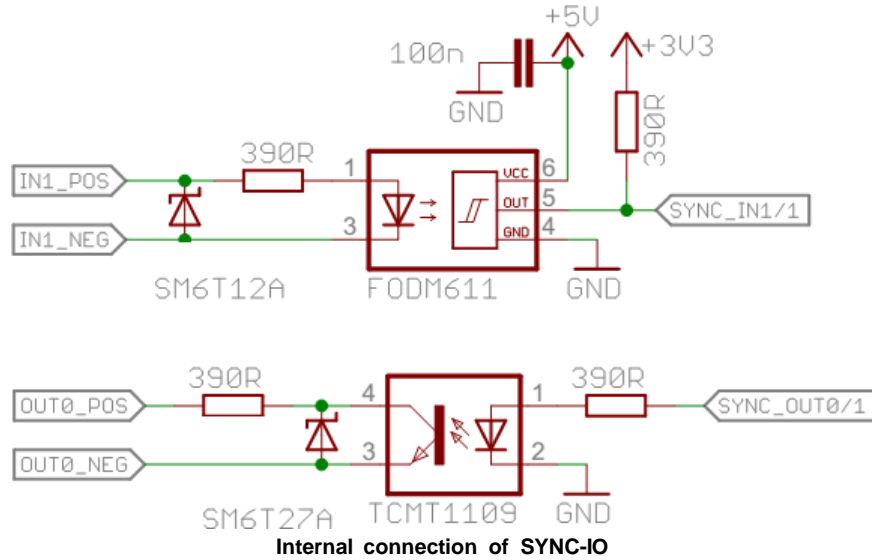

#### 3.1.1 Power consumption

Standby	0,4A; 5V
---------	----------

### 3.1.2 Block schematic

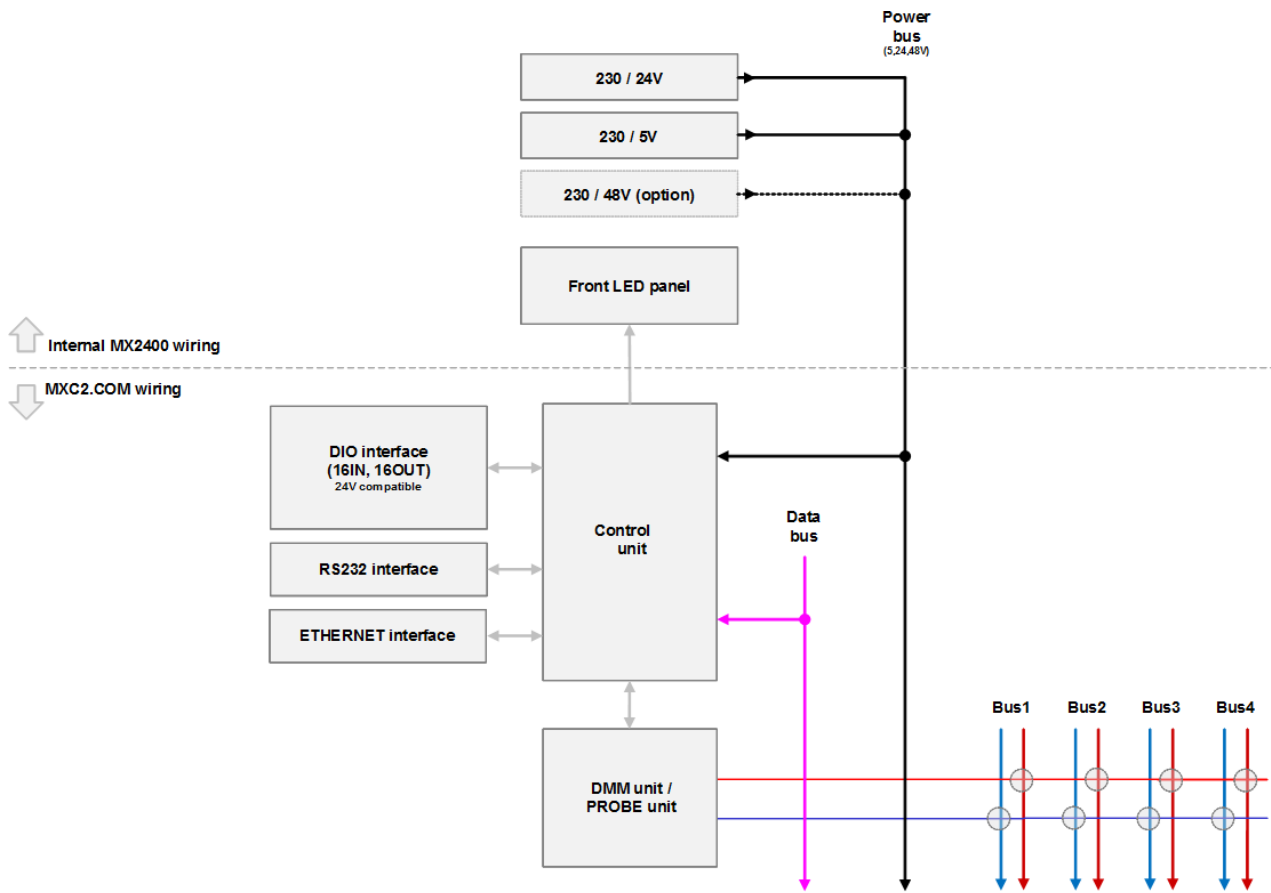

### 3.2 MXC2-DEV-4/2/2

Device connection card allows to connect especially the measurement instruments or route the bus signals to the output.

The secondary function is connect up to 2 external power supplies and route them to the bus.

External supply positive line can be routed to the I-MEAS. The switching between direct or detoured path over I-MEAS is done without the interrupt of current flow (it takes about 35ms). Only one external power supply can be detoured at a time.

Maximum current over Channels-to-Bus relays is 500mA at 50V.

Maximum current over PS1IN or PS2IN from external power supply are limited by card revision.

Card revision	Max. switching current	Continuous current
A	0,5 A / 50VDC	1 A
B	3 A / 50VDC	6 A

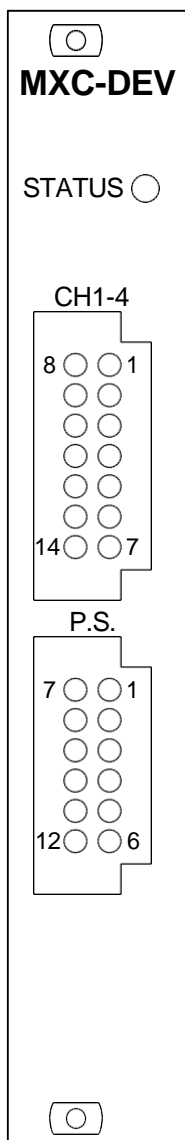

**STATUS** Status LED

**CH1-4 - Multimeter and internal bus connector:**

- 1 CH-1 high
- 2 CH-2 high
- 3 CH-3 high
- 4 CH-4 high
- 5 MEAS high
- 6 SENSE high
- 7 I-MEAS low
- 8 CH-1 low
- 9 CH-2 low
- 10 CH-3 low
- 11 CH-4 low
- 12 MEAS low
- 13 SENSE low
- 14 I-MEAS high

MEAS, SENS and I-MEAS are intended for external multimeter (such as Agilent 344xx series)

**P.S. - External and internal power supplies input/output:**

- 1 PS1IN (+)
- 2 PS2IN (+)
- 3 PS1OUT (+)
- 4 PS2OUT (+)
- 5 +24V power output
- 6 +5V power output
- 7 PS1IN (-)
- 8 PS2IN (-)
- 9 PS1OUT (-)
- 10 PS2OUT (-)
- 11 GND 24V
- 12 GND 5V

### 3.2.1 Power consumption

Card revision	A
Standby	65mA; 5V
Relays - PS to bus connection (8x)	0,22A; 5V
Relays - PS1/2 on/off (2x)	0,14A; 5V
Relays - multimeter SENS+MEAS (8x)	0,16A; 5V
Relays - bus multiplex (16x)	0,31A; 5V

Card revision	B
Standby	65mA; 5V
Relays - PS to bus connection (8x)	55mA; 24V
Relays - PS1/2 on/off (2x)	14mA; 24V
Relays - multimeter SENS+MEAS (8x)	0,16A; 5V
Relays - bus multiplex (16x)	0,31A; 5V

### 3.2.2 Block schematic

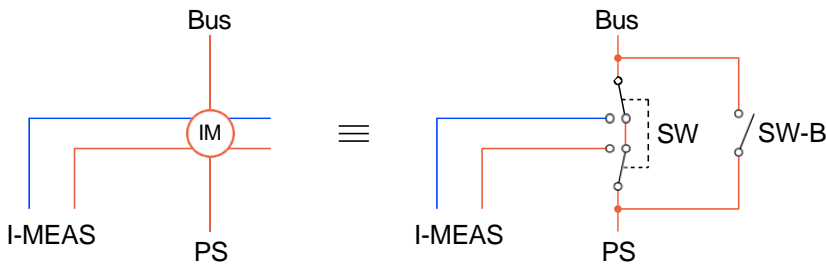
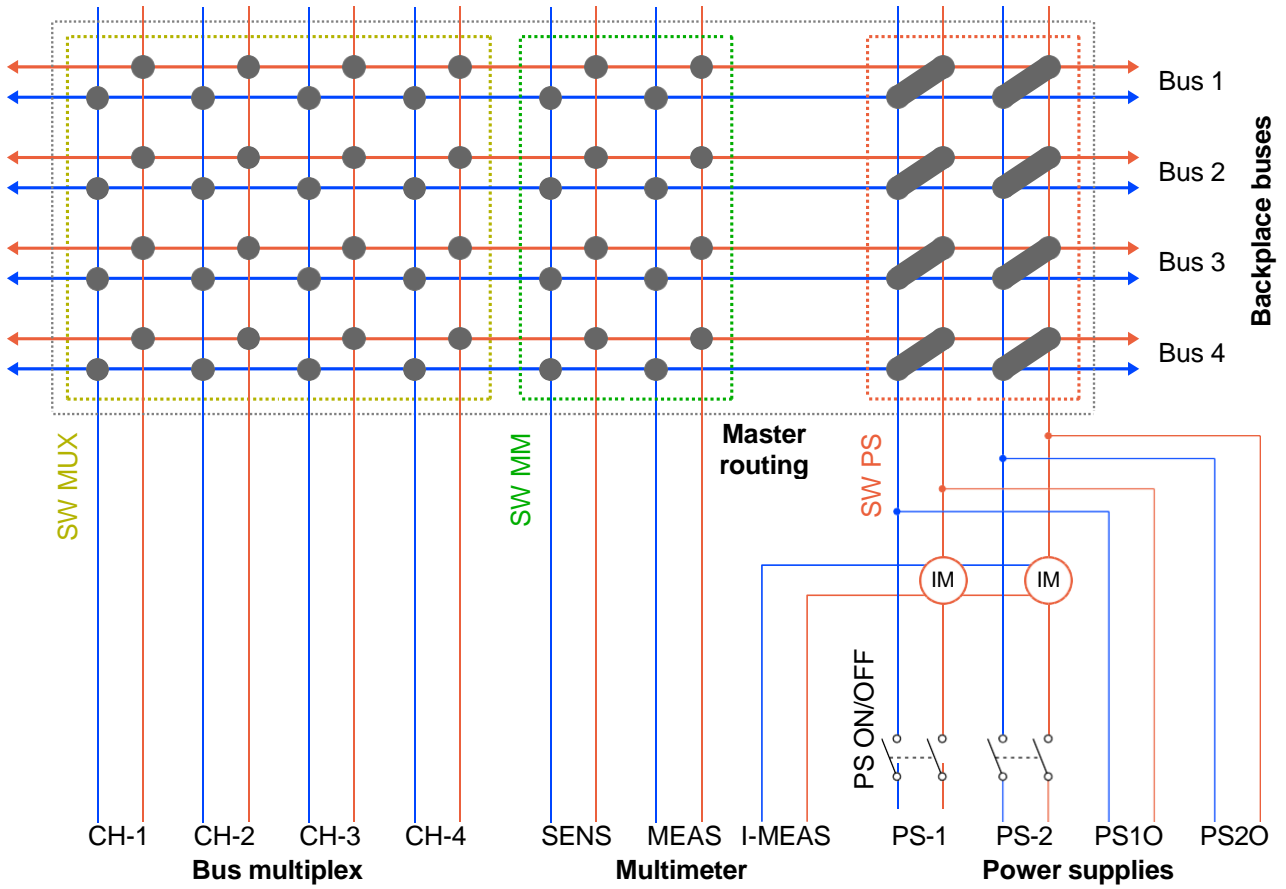



### 3.3 MXC2-DEV-4D

Simple low-cost variant of the MXC2-DEV-4/2/2 device connection card. This is passive card without any controller and connecton to MX2400 data bus, it just directly route BUS signals and internal power supplies to the output. This card has no representation in the software.

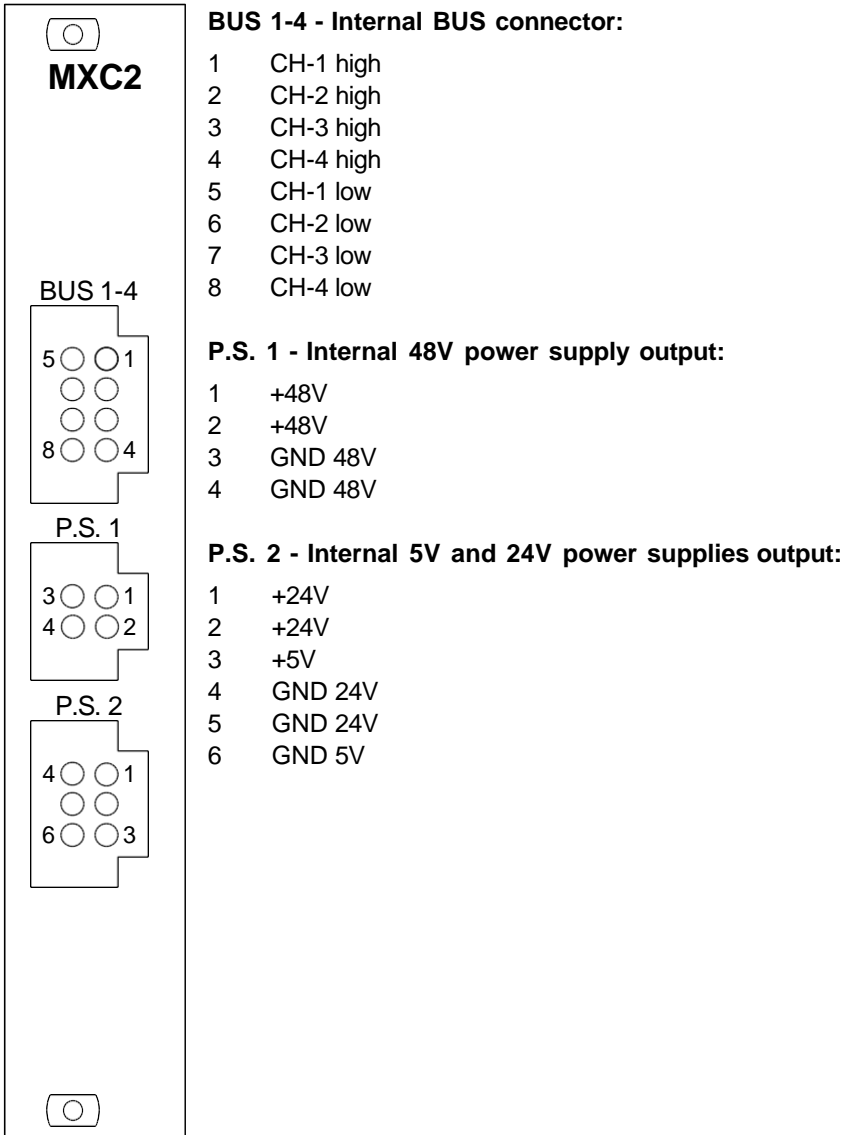

#### 3.3.1 Power consumption

None (passive card).

### 3.3.2 Block schematic

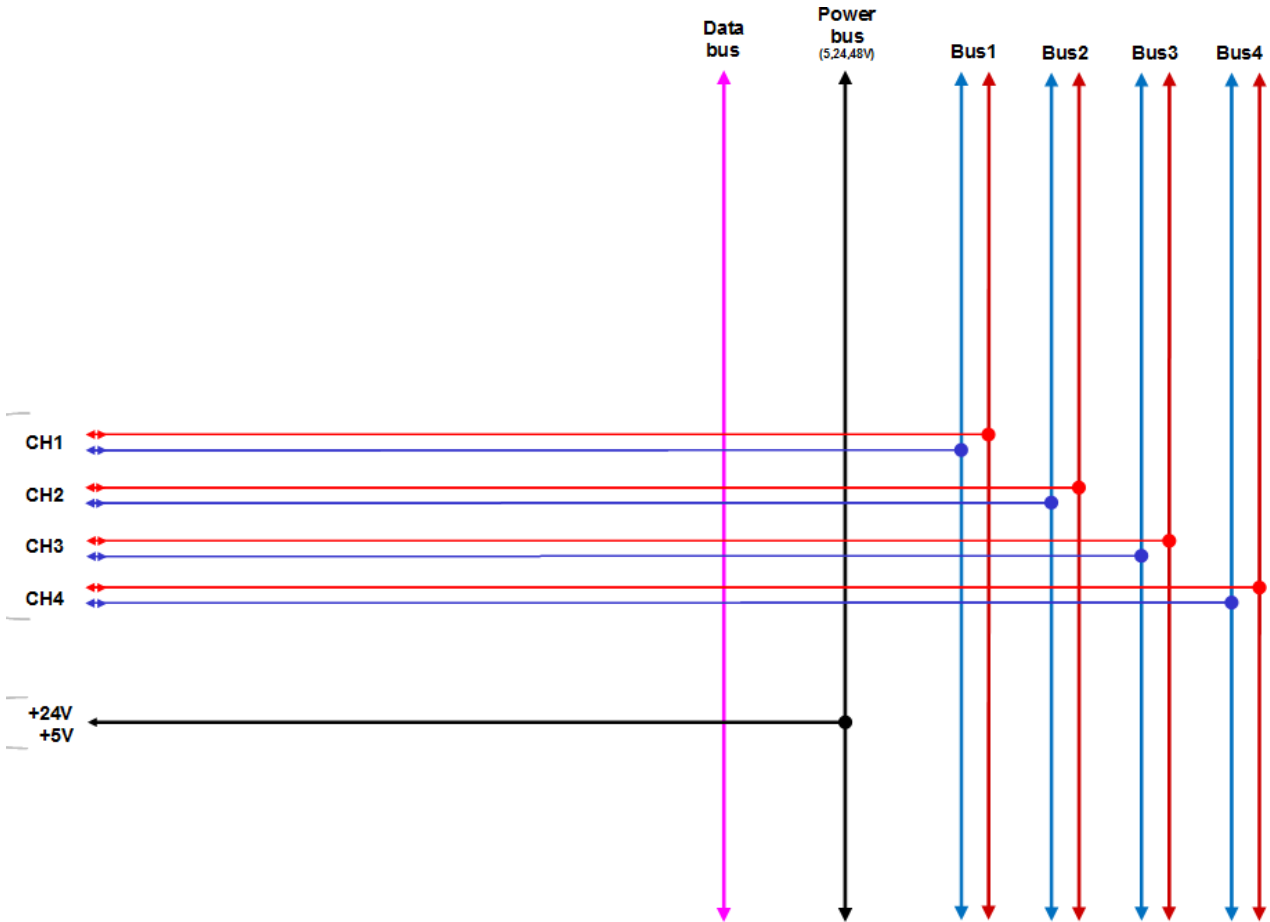

### 3.4 MXC2-LCMX-32

Low-current/low-voltage matrix card (up to 500mA/50V) with 32 test-points. The TP connector is divided to two separated buses (A, C), which can be routed to main buses via routing relays. The card features a diagnostics functionality, which can identify permanently shorted or open any TP relay.

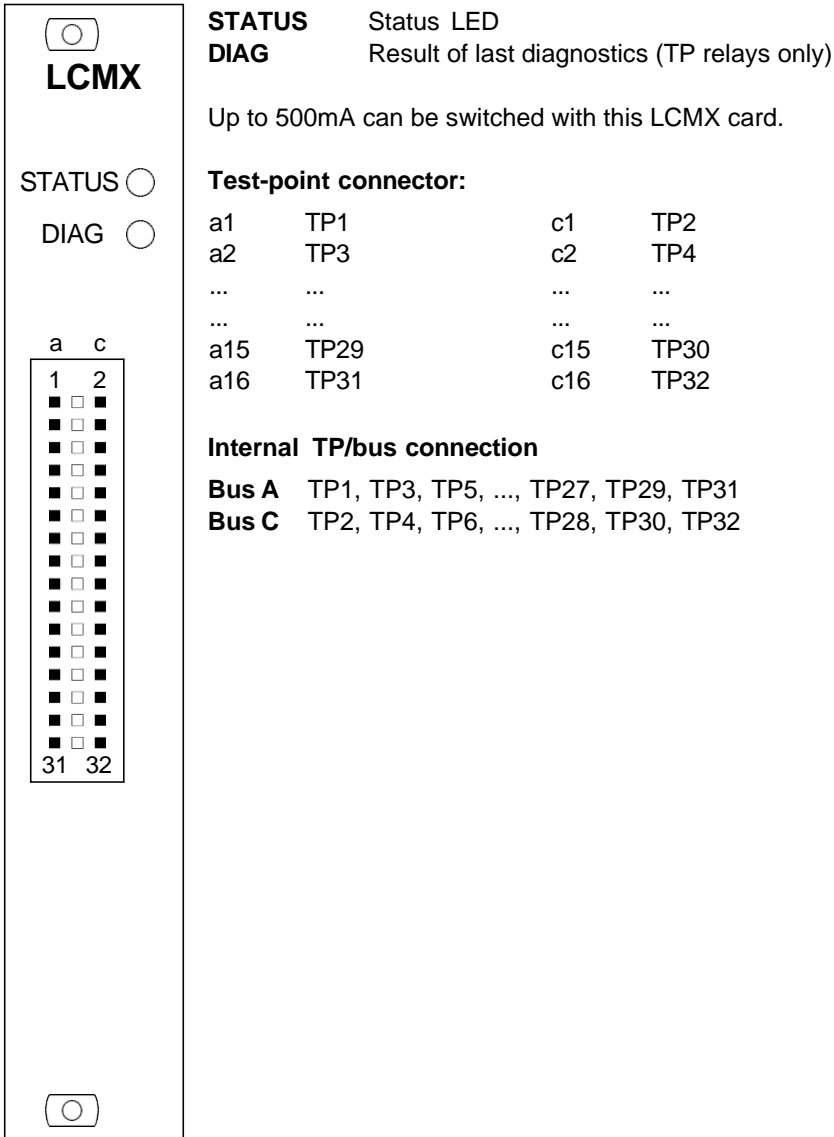

#### 3.4.1 Power consumption

Standby	65mA; 5V
Relays - TP L (32x)	0,3A; 5V
Relays - TP L+H (64x)	0,6A; 5V
Relays - routing (16x)	0,5A; 5V

### 3.4.2 Relay placement

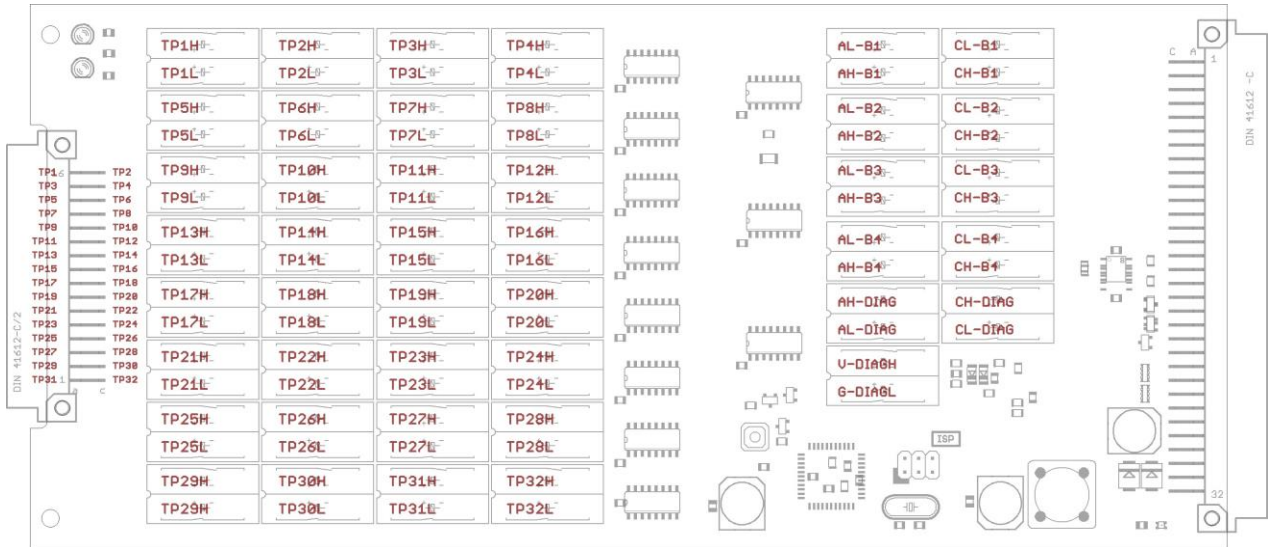

Top view on the LCMX card

Relay	Count	Description
TPnL, TPnH	64	Test-point relays. Each test-point consist of two relays - TPnL and TPnH, where n is the test-point number (1 to 32). Relays ending by "H" connects specified test-point to HIGH bus and "L" to LOW bus.
AL/AH-Bn, CL/CH-Bn	16	Routing relays. These relays connects internal card's buses A and C to specified main (backplane) buses B1 to B4.
*DIAG*	6	Diagnostic relays. Used for TP relays diagnostics. Internal usage only. These relays cannot be diagnosed.

### 3.4.3 Block schematic

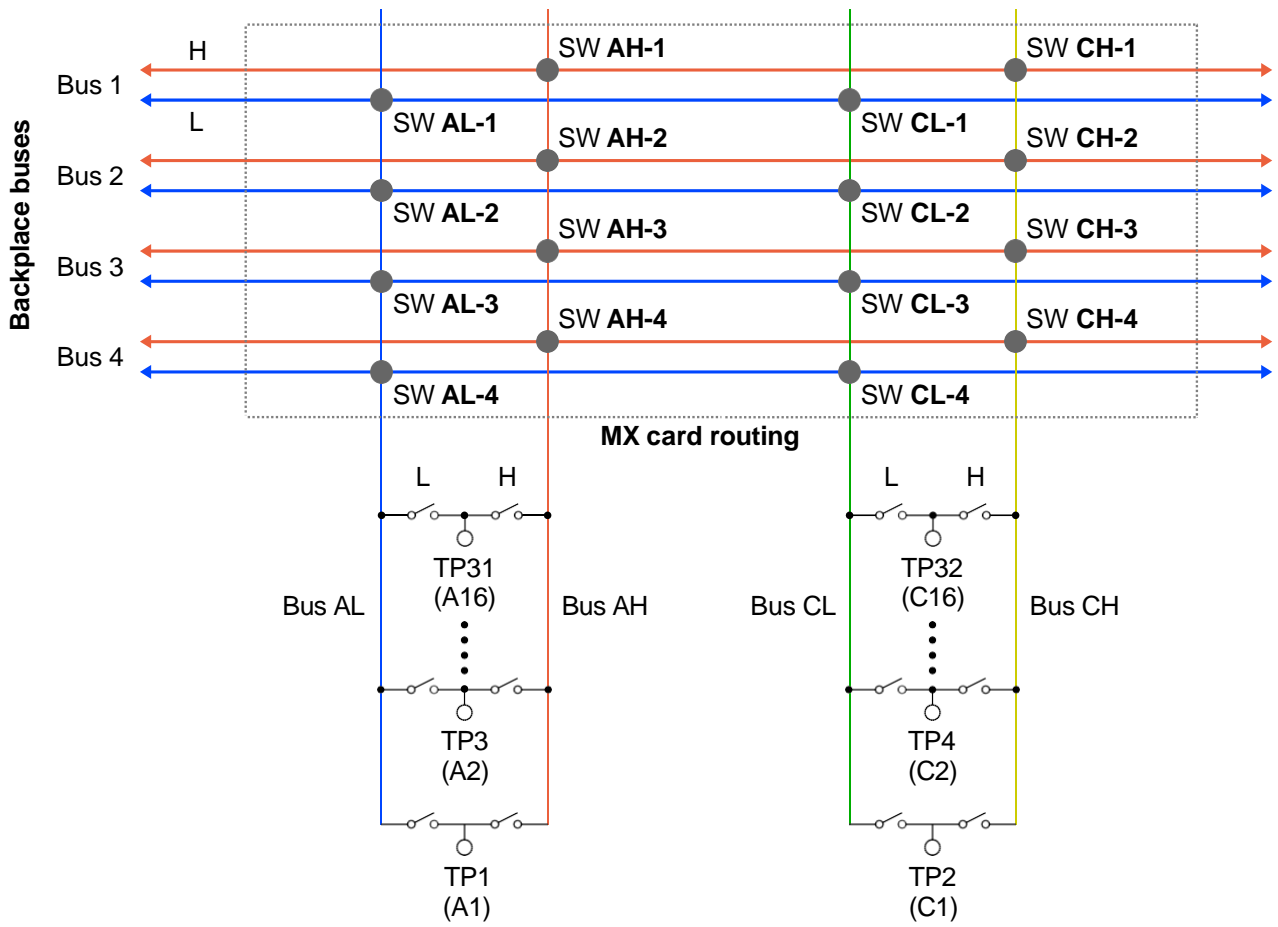

### 3.5 MXC2-HCMX-16

High-current/middle-voltage matrix card (up to 5A/250V) with 16 test-points. The TP connector is divided to two separated buses (A, C), which can be routed to main buses via routing relays. The card features a diagnostics functionality, which can identify permanently shorted or open any TP relay.

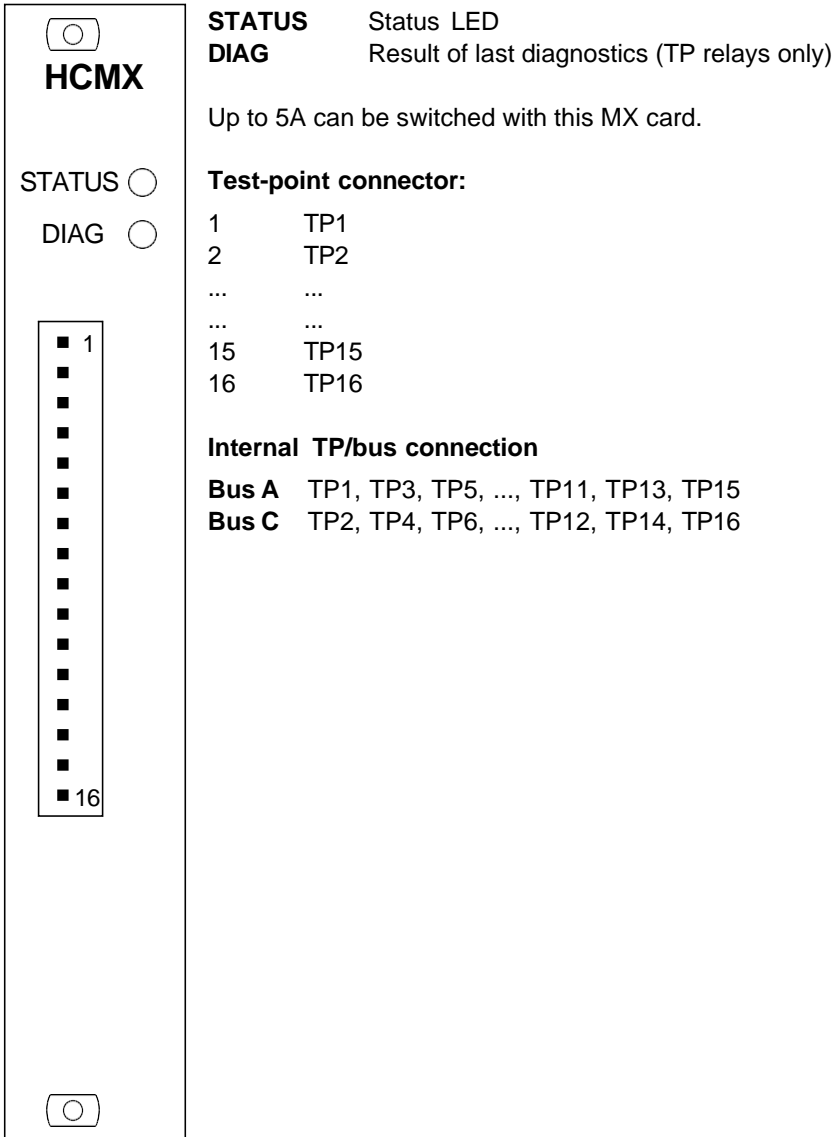

#### 3.5.1 Power consumption

Standby	65mA; 5V
Relays - TP L (16x)	0,11A; 24V
Relays - TP L+H (32x)	0,22A; 24V
Relays - routing (16x)	0,11A; 24V

### 3.5.2 Relay placement

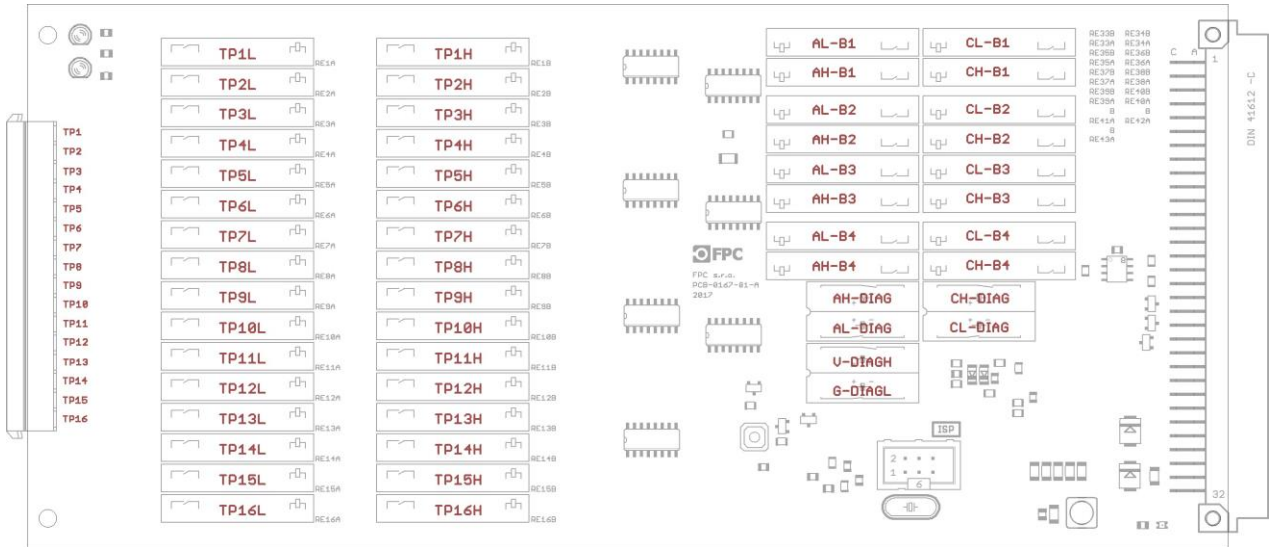

Top view on the HCMX card

Relay	Count	Description
TPnL, TPnH	32	Test-point relays. Each test-point consist of two relays - TPnL and TPnH, where n is the test-point number (1 to 16). Relays ending by "H" connects specified test-point to HIGH bus and "L" to LOW bus.
AL/AH-Bn, CL/CH-Bn	16	Routing relays. These relays connects internal card's buses A and C to specified main (backplane) buses B1 to B4.
*DIAG*	6	Diagnostic relays. Used for TP relays diagnostics. Internal usage only. These relays cannot be diagnosed.

### 3.5.3 Block schematic

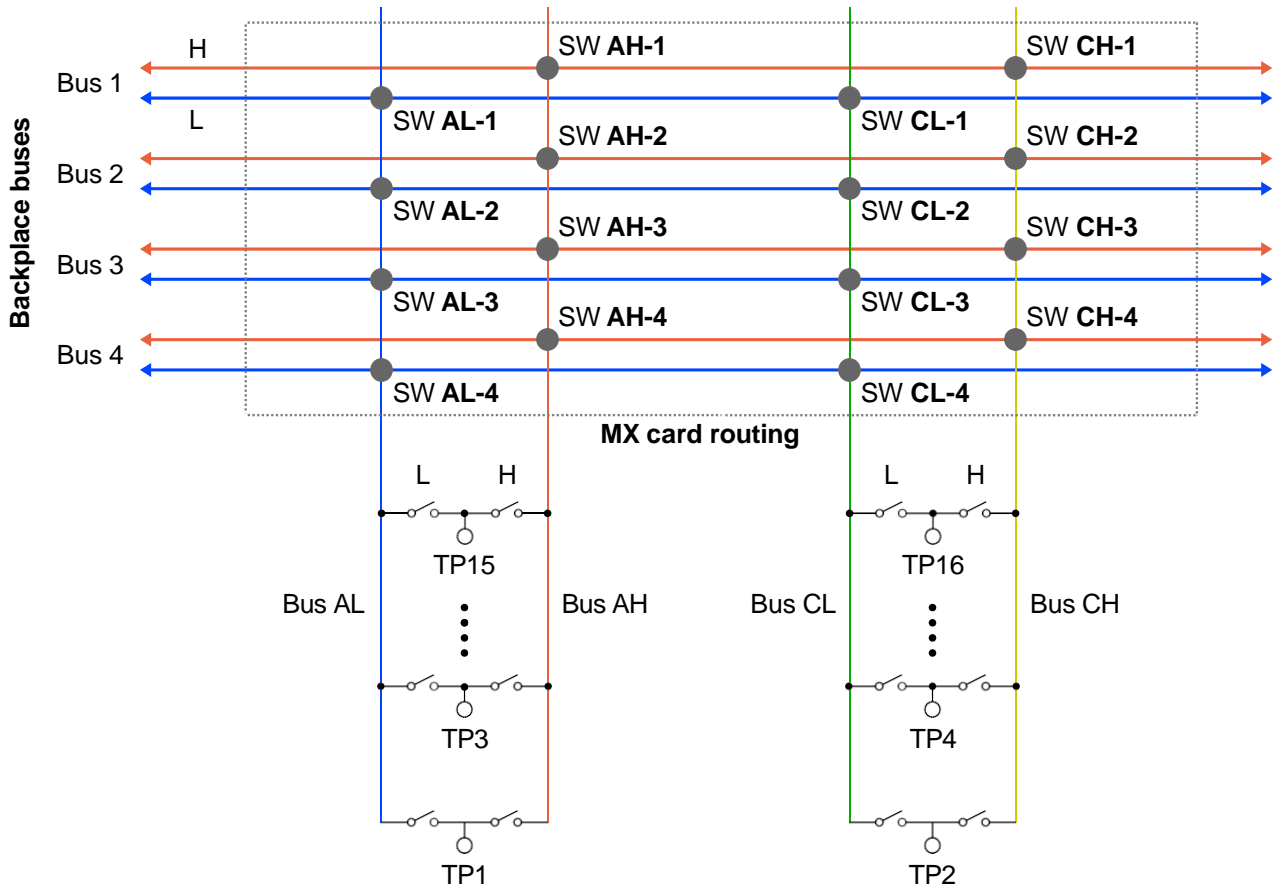



### 3.6 MXC2-DIO-64

The card has 64 inputs and open-drain outputs.

- This IOs is separated into 4 groups and every of them can be connected to GND, 5V or 24V.
- Input voltage range: 4,5V - 50V
- Open-drain transistor on resistance is ~100mΩ.
- Open-drain transistor drain current is 2,1A continuous, but we recommend maximally 1A. (For more info see [IRLML0060TRPBF](#) datasheet)
- Sum of all active transistors drain currents must not exceed 5A continuous.

The card has self diagnostics feature, which can detect damaged parts (transistors / transil-diodes / optocouplers).

#### Internal connection

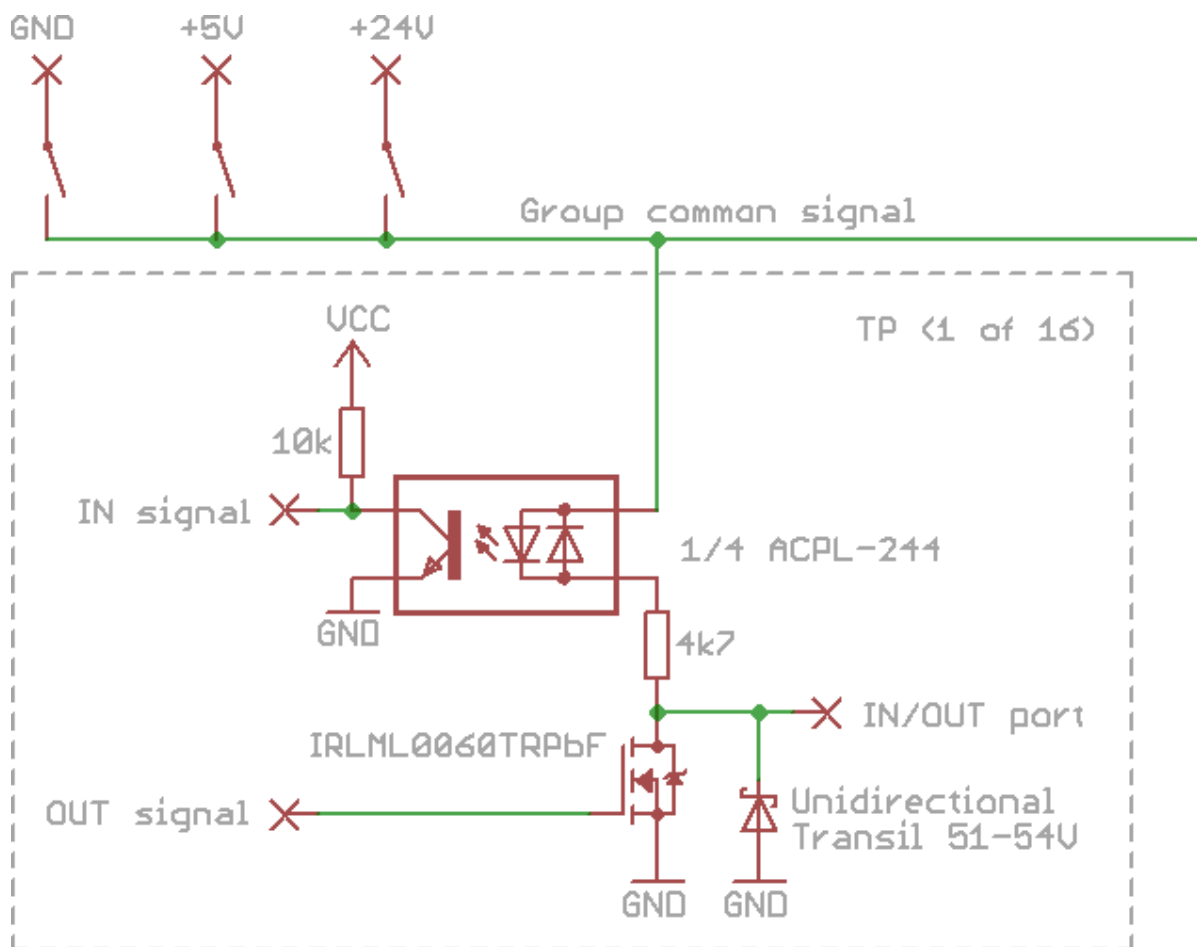

#### 3.6.1 Power consumption

Card (standby)	52mA; 5V
Card - 4 groups activated	92mA; 5V
Only inputs - all 64x activated	64mA; 5V
Only inputs - all 64x activated	290mA; 24V

### 3.6.2 Panel description

**STATUS**      Status LED  
**DIAG**        Result of last diagnostics

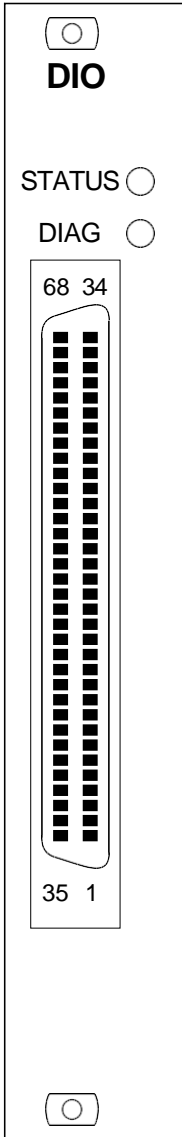

68	GND
67	GND
66	5V
65	24V
64	DIO-63
63	DIO-62
62	DIO-61
61	DIO-60
60	DIO-59
59	DIO-58
58	DIO-57
57	DIO-56
56	DIO-55
55	DIO-54
54	DIO-53
53	DIO-52
52	DIO-51
51	DIO-50
50	DIO-49
49	DIO-48
48	DIO-47
47	DIO-46
46	DIO-45
45	DIO-44
44	DIO-43
43	DIO-42
42	DIO-41
41	DIO-40
40	DIO-39
39	DIO-38
38	DIO-37
37	DIO-36
36	DIO-35
35	DIO-34

34	DIO-33
33	DIO-32
32	DIO-31
31	DIO-30
30	DIO-29
29	DIO-28
28	DIO-27
27	DIO-26
26	DIO-25
25	DIO-24
24	DIO-23
23	DIO-22
22	DIO-21
21	DIO-20
20	DIO-19
19	DIO-18
18	DIO-17
17	DIO-16
16	DIO-15
15	DIO-14
14	DIO-13
13	DIO-12
12	DIO-11
11	DIO-10
10	DIO-9
9	DIO-8
8	DIO-7
7	DIO-6
6	DIO-5
5	DIO-4
4	DIO-3
3	DIO-2
2	DIO-1
1	DIO-0

DIO groups are distinguished by colors.

### 3.7 MXC2-DIO-64I

The card has 64 inputs and open-drain outputs.

Inputs and output are isolated from the MX2400 power supplies and the ground.

- This IOs has two common rails which can has different voltages to supply inputs (VIN0=0-31 input, VIN1=32-63 input)
- Input voltage range: 4,5V - 50V
- Open-drain transistor on resistance is ~100mΩ.
- Open-drain transistor drain current is 2,1A continuous, but we recommend maximally 1A. (For more info see [IRLML0060TRPBF](#) datasheet)
- Sum of all active transistors drain currents must not exceed 5A continuous.

The card has self diagnostics feature, which can detect damaged parts (transistors / transil-diodes / optocouplers).

When card is doing the self-diagnostics feature, the **VIN0- and VIN1-** will be connected to the **MX2400 ground!**

#### Internal connection

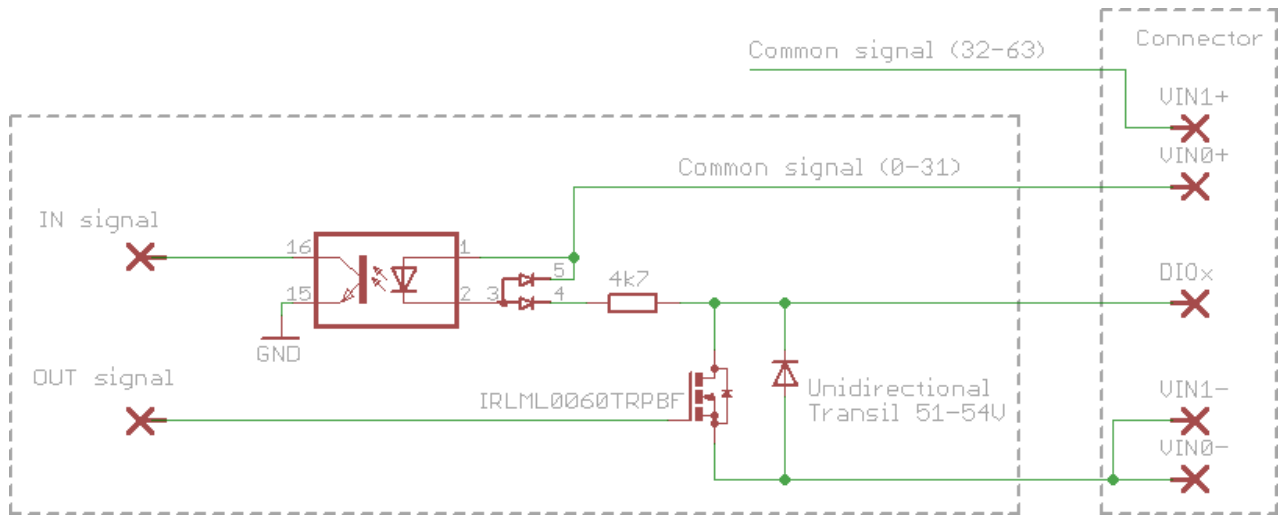

#### 3.7.1 Power consumption

Card (standby)	83mA; 5V
Only inputs - all 64x activated	63mA; 5V
Only inputs - all 64x activated	288mA; 24V

#### 3.7.2 Panel description

**STATUS**      Status LED  
**DIAG**        Result of last diagnostics

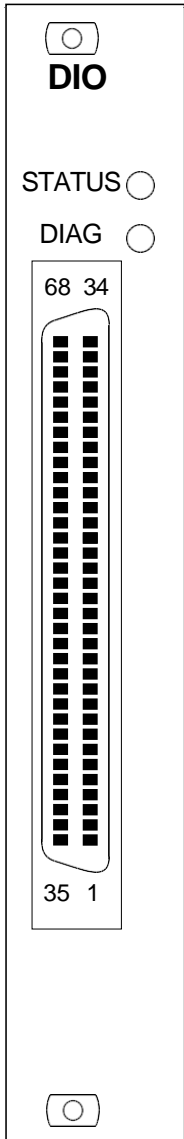

68	VIN1- (GND)
67	VIN0- (GND)
66	VIN1+
65	VIN0+
64	DIO-63
63	DIO-62
62	DIO-61
61	DIO-60
60	DIO-59
59	DIO-58
58	DIO-57
57	DIO-56
56	DIO-55
55	DIO-54
54	DIO-53
53	DIO-52
52	DIO-51
51	DIO-50
50	DIO-49
49	DIO-48
48	DIO-47
47	DIO-46
46	DIO-45
45	DIO-44
44	DIO-43
43	DIO-42
42	DIO-41
41	DIO-40
40	DIO-39
39	DIO-38
38	DIO-37
37	DIO-36
36	DIO-35
35	DIO-34

34	DIO-33
33	DIO-32
32	DIO-31
31	DIO-30
30	DIO-29
29	DIO-28
28	DIO-27
27	DIO-26
26	DIO-25
25	DIO-24
24	DIO-23
23	DIO-22
22	DIO-21
21	DIO-20
20	DIO-19
19	DIO-18
18	DIO-17
17	DIO-16
16	DIO-15
15	DIO-14
14	DIO-13
13	DIO-12
12	DIO-11
11	DIO-10
10	DIO-9
9	DIO-8
8	DIO-7
7	DIO-6
6	DIO-5
5	DIO-4
4	DIO-3
3	DIO-2
2	DIO-1
1	DIO-0

## 3.8 MXC2-DI-ISO-32

The card has 32 fully isolated bidirectional inputs

- Channel working voltage range: 4,0V - 32V
- Channel working current: 640uA - 6,6mA
- Channel reaction time: < 1ms
- Channel to channel insulation: 100 Vrms
- Channel bidirectional transil protection (33V / 38,6V surge)
- Internal GND and 24V (fused by 200mA polyswitch) in the connector (when non isolated input is needed without another power supply)

This card not has the self-diagnostics feature on board.

It must be diagnosed by using a another MXC2-DIO-64 (without PSW2 polyfuse on the board) in the system and inter-connected them by 1:1 SCSI 68pin cable.

### Internal connection

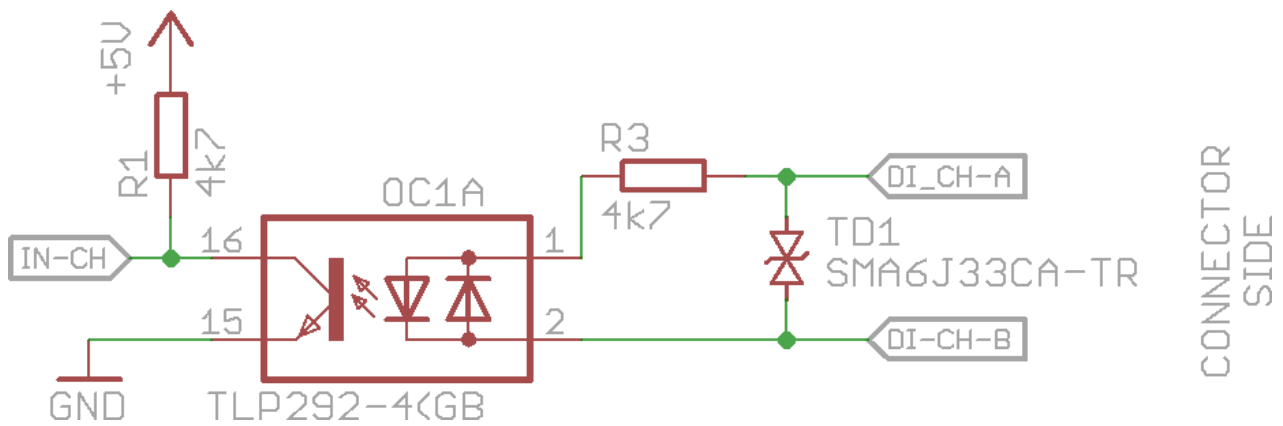

### 3.8.1 Power consumption

Standby	59mA; 5V
All (32) inputs activated	70mA; 5V
All (32) inputs activated where the 24V from connector is used for pullup	72mA; 24V

### 3.8.2 Panel description

<b>STATUS</b>	Status LED
<b>DIAG</b>	Result of last diagnostics

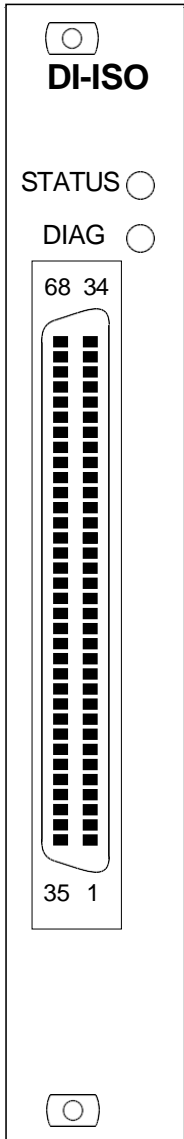

68	GND
67	GND
66	24V (fused)
65	24V (fused)
64	DI-31-B
63	DI-31-A
62	DI-30-B
61	DI-30-A
60	DI-29-B
59	DI-29-A
58	DI-28-B
57	DI-28-A
56	DI-27-B
55	DI-27-A
54	DI-26-B
53	DI-26-A
52	DI-25-B
51	DI-25-A
50	DI-24-B
49	DI-24-A
48	DI-23-B
47	DI-23-A
46	DI-22-B
45	DI-22-A
44	DI-21-B
43	DI-21-A
42	DI-20-B
41	DI-20-A
40	DI-19-B
39	DI-19-A
38	DI-18-B
37	DI-18-A
36	DI-17-B
35	DI-17-A

34	DI-16-B
33	DI-16-A
32	DI-15-B
31	DI-15-A
30	DI-14-B
29	DI-14-A
28	DI-13-B
27	DI-13-A
26	DI-12-B
25	DI-12-A
24	DI-11-B
23	DI-11-A
22	DI-10-B
21	DI-10-A
20	DI-09-B
19	DI-09-A
18	DI-08-B
17	DI-08-A
16	DI-07-B
15	DI-07-A
14	DI-06-B
13	DI-06-A
12	DI-05-B
11	DI-05-A
10	DI-04-B
9	DI-04-A
8	DI-03-B
7	DI-03-A
6	DI-02-B
5	DI-02-A
4	DI-01-B
3	DI-01-A
2	DI-00-B
1	DI-00-A

### 3.9 MXC2-DO-ISO-32

The card has 32 fully isolated bidirectional solid state outputs:

- Channel maximum voltage: 32V
- Channel maximum current: 400mA @ <50°C (500mA @ <25°C)
- Channel reaction time: <1ms
- Channel to channel insulation: 100 Vrms
- Channel bidirectional transil protection (33V / 38,6V surge)
- Internal GND and 24V (fused by 200mA polyswitch) in the connector

This card not has the self-diagnostics feature on board.

It must be diagnosed by using a another MXC2-DIO-64 (without PSW2 polyfuse on the board) in the system and inter-connected them by 1:1 SCSI 68pin cable.

#### Internal connection

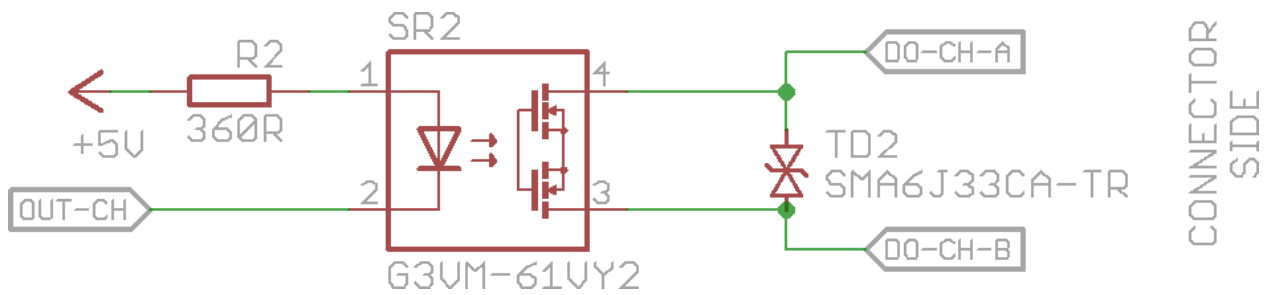

#### 3.9.1 Power consumption

Standby	59mA; 5V
All (32) outputs activated	325mA; 5V

#### 3.9.2 Panel description

<b>STATUS</b>	Status LED
<b>DIAG</b>	Result of last diagnostics

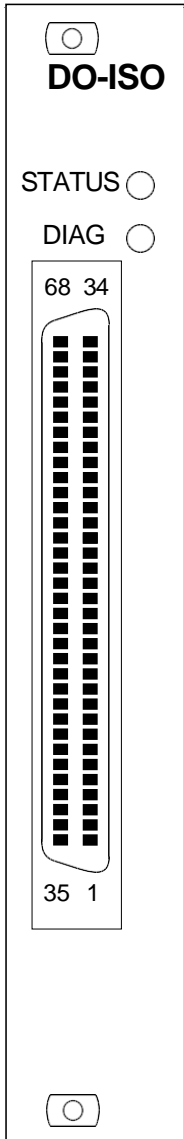

68	GND
67	GND
66	24V (fused)
65	24V (fused)
64	DO-31-B
63	DO-31-A
62	DO-30-B
61	DO-30-A
60	DO-29-B
59	DO-29-A
58	DO-28-B
57	DO-28-A
56	DO-27-B
55	DO-27-A
54	DO-26-B
53	DO-26-A
52	DO-25-B
51	DO-25-A
50	DO-24-B
49	DO-24-A
48	DO-23-B
47	DO-23-A
46	DO-22-B
45	DO-22-A
44	DO-21-B
43	DO-21-A
42	DO-20-B
41	DO-20-A
40	DO-19-B
39	DO-19-A
38	DO-18-B
37	DO-18-A
36	DO-17-B
35	DO-17-A

34	DO-16-B
33	DO-16-A
32	DO-15-B
31	DO-15-A
30	DO-14-B
29	DO-14-A
28	DO-13-B
27	DO-13-A
26	DO-12-B
25	DO-12-A
24	DO-11-B
23	DO-11-A
22	DO-10-B
21	DO-10-A
20	DO-09-B
19	DO-09-A
18	DO-08-B
17	DO-08-A
16	DO-07-B
15	DO-07-A
14	DO-06-B
13	DO-06-A
12	DO-05-B
11	DO-05-A
10	DO-04-B
9	DO-04-A
8	DO-03-B
7	DO-03-A
6	DO-02-B
5	DO-02-A
4	DO-01-B
3	DO-01-A
2	DO-00-B
1	DO-00-A



## 3.10 MXC2-BUSEX

The BUS extension card is used for [interconnect](#) two MX2400 racks to work together as a one device.

Power supply traces is splitted up on this card by default and if is needed, can be easily soldered together.

Solder jumper name	Description
J5A	+5V rail
J5B	+5V rail
J24A	+24V rail
J24B	+24V rail
J48AG	Ground of +48V rail
J48BG	Ground of +48V rail
J48A	+48V rail
J48B	+48V rail

### 3.10.1 Panel connector description

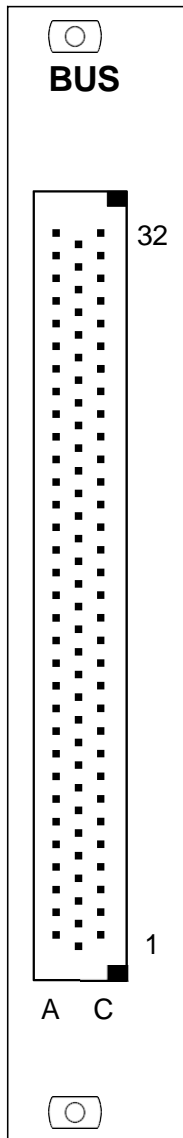

32A	+48V
31A	+48V
30A	GND (48V)
29A	GND (48V)
28A	<reserved>
27A	L1
26A	H1
25A	L2
24A	H2
23A	L3
22A	H3
21A	L4
20A	H4
19A	<reserved>
18A	<reserved>
17A	EXT_RST
16A	RXP
15A	TXP
14A	ROUT_S
13A	BUSY_S
12A	RIN_S
11A	ADDR0
10A	ADDR1
9A	ADDR2
8A	+24V
7A	+24V
6A	GND (24V)
5A	GND (24V)
4A	+5V
3A	+5V
2A	GND (5V)
1A	GND (5V)

32C	+48V
31C	+48V
30C	GND (48V)
29C	GND (48V)
28C	<reserved>
27C	L1
26C	H1
25C	L1
24C	H2
23C	L3
22C	H3
21C	L4
20C	H4
19C	<reserved>
18C	<reserved>
17C	<reserved>
16C	RXN
15C	TXN
14C	ERR_S
13C	CLR_S
12C	INT_S
11C	ADDR3
10C	ADDR4
9C	ADDREX
8C	+24V
7C	+24V
6C	GND (24V)
5C	GND (24V)
4C	+5V
3C	+5V
2C	GND (5V)
1C	GND (5V)

